

Only the Avatar Anaerobic Digester offers all these features:

- First scalable system with a modular design platform
- Targeted to mid-sized operations
- Simple to operate and maintain
- Above ground with decreased space requirements
- Varying configurations to maximize space utilization

AVATAR
A RENEWABLE ENERGY COMPANY

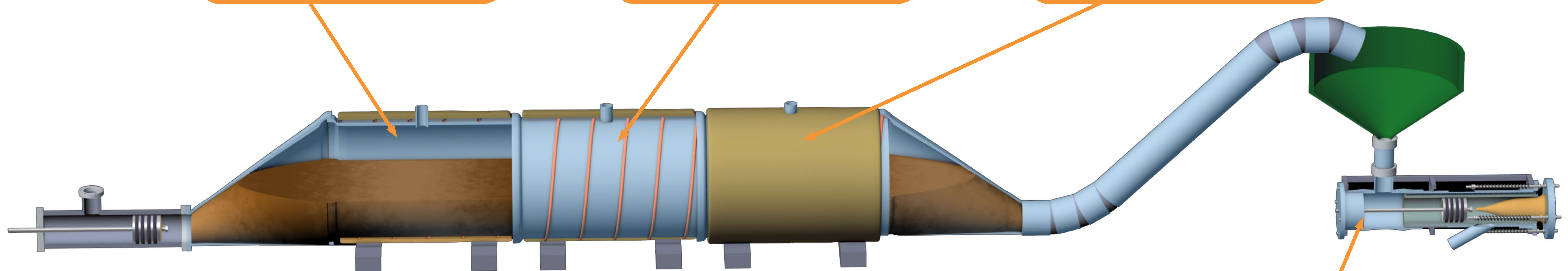
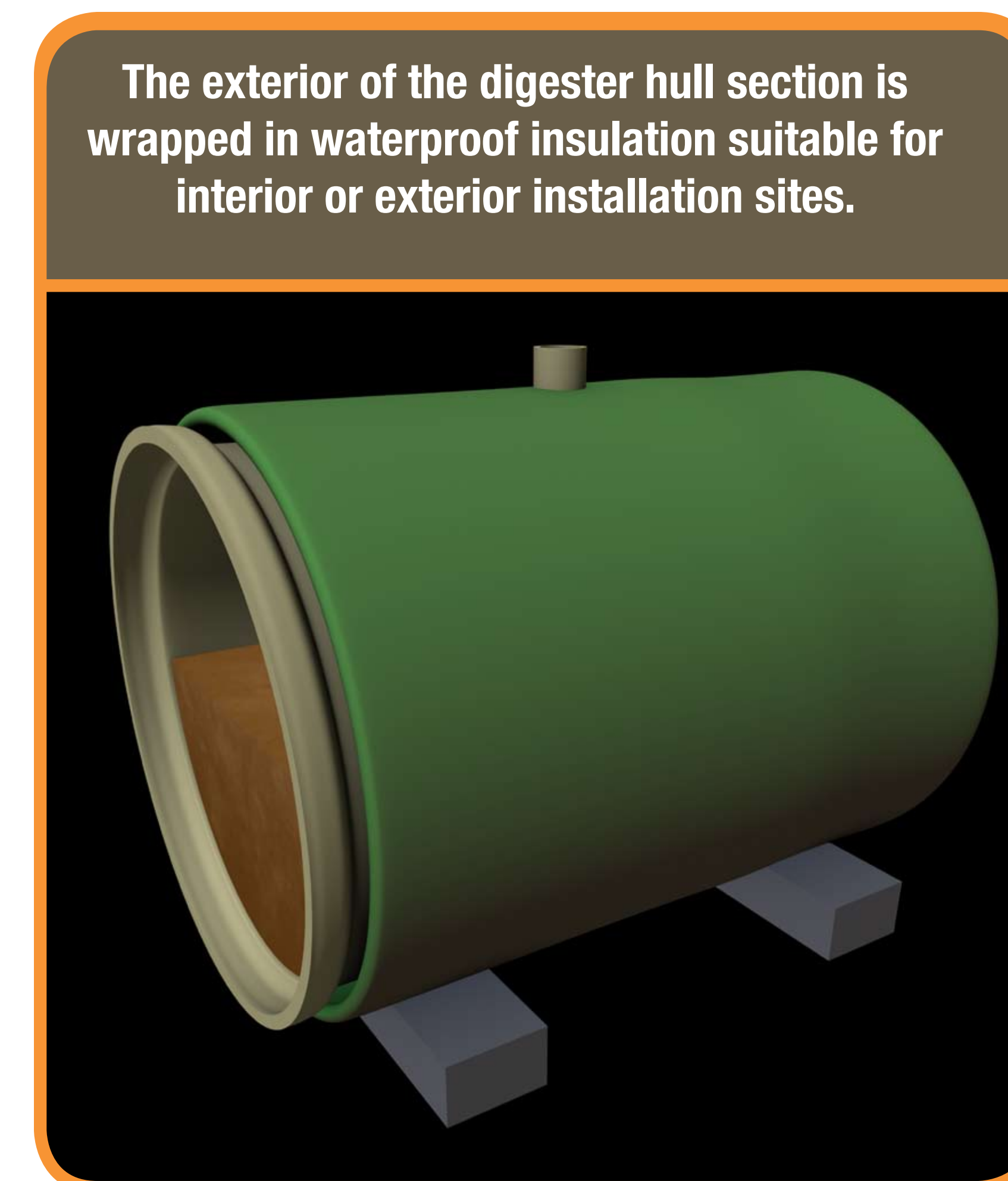
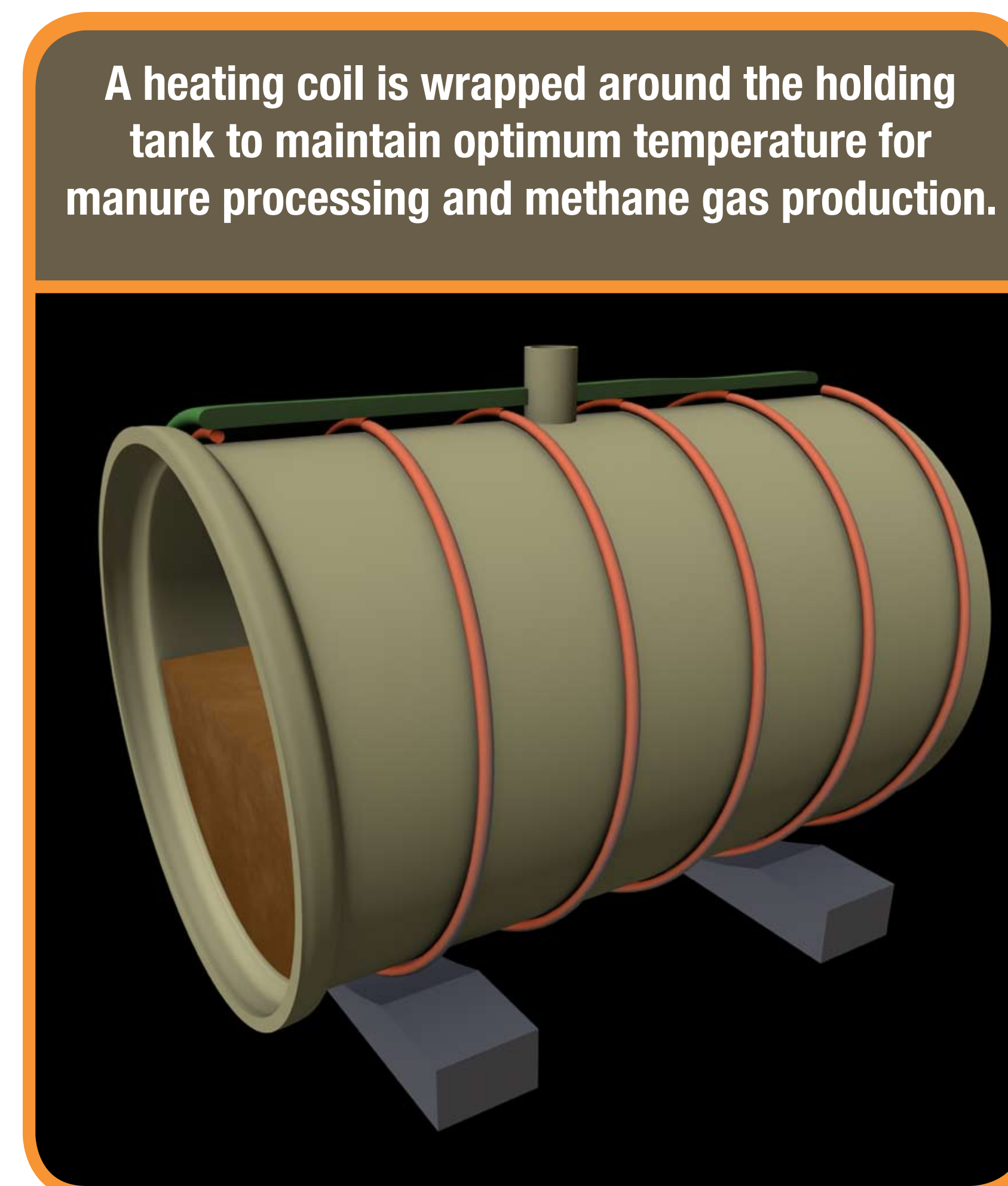
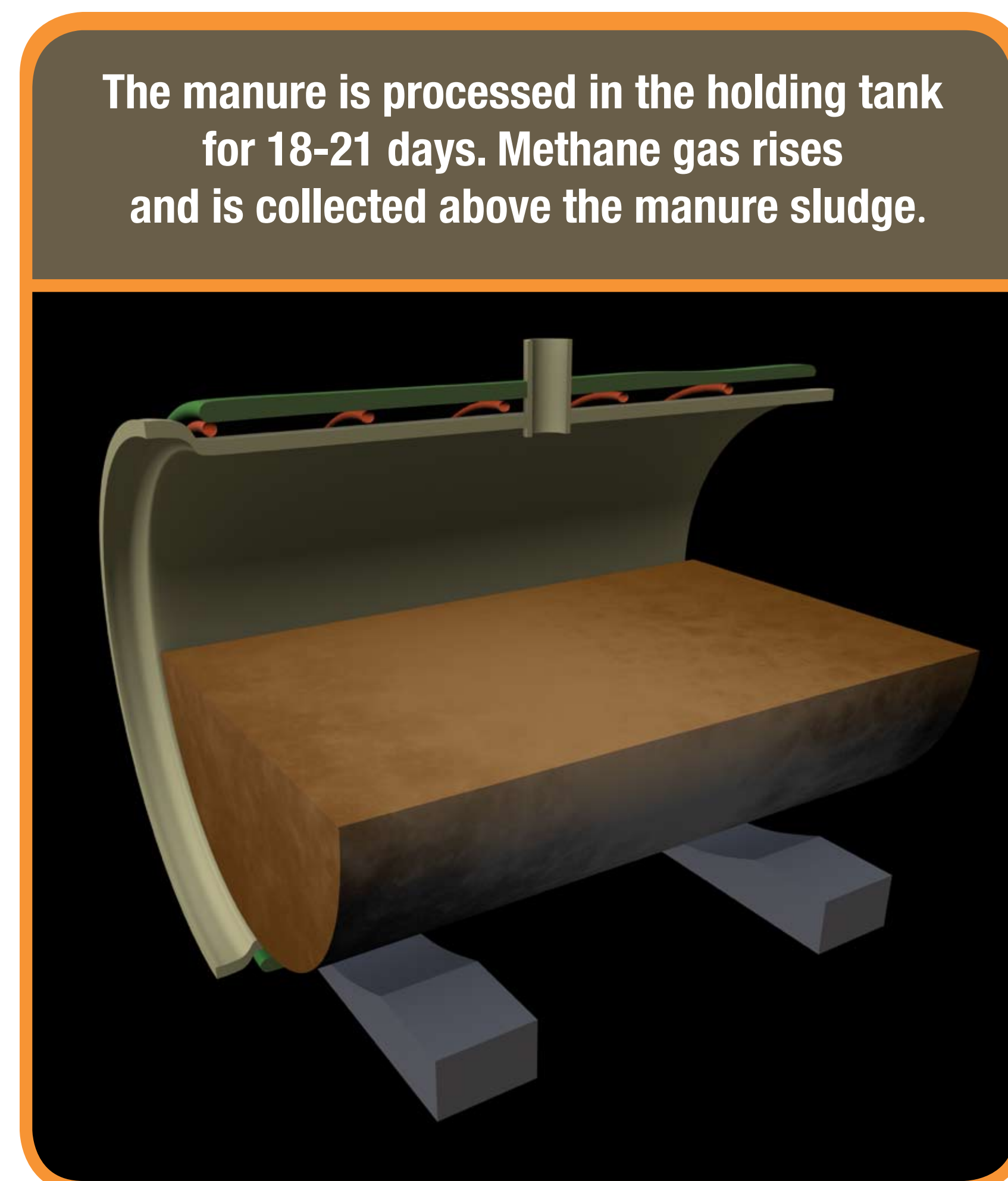

The complete Avatar Digester. This cross view shows the piston pump injection of manure through processing to separator.

AVATARENERGY.COM
1-877-AVATAR-0
1-877-282-8270

